

CAN MAN®

X6

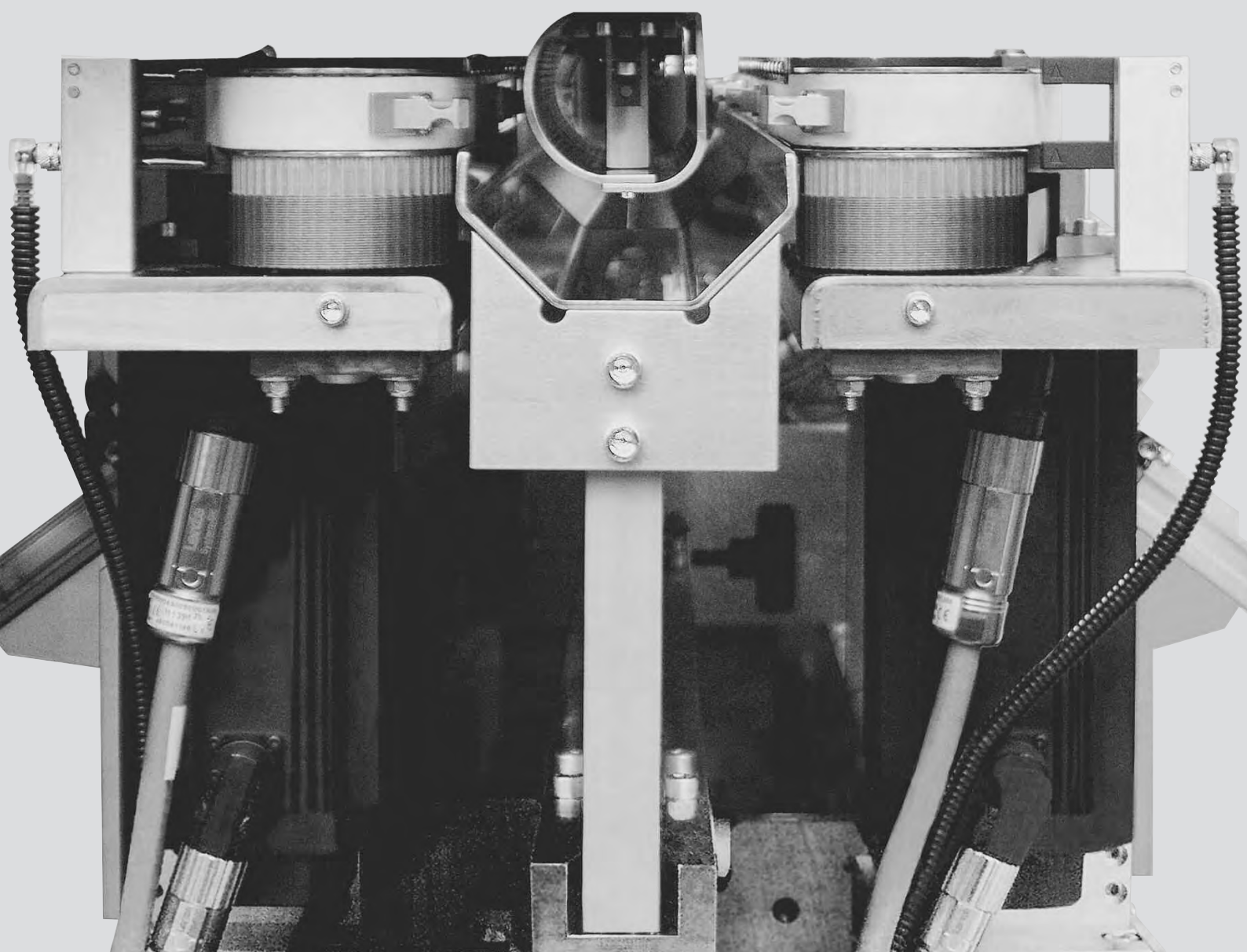

- Purpose The X6-Series WeldCENTER™ of Can Man is a medium speed welder concept for food and aerosol productions of up to 450 cpm with welding speed ranging from 30-90 m/min.
- QuickChange™ Fully automatic canbody height change – 2 minutes and you are ready for production again!
- PowerFOIL™ Saves up to 50% copper wire using wire-ø of 1 mm instead of 1.38 mm. Check out the savings you'll achieve using the PowerFOIL™ calculator on our website.
- XPLANE™ Fast and precise welding roll re-adjustment by turning one eccentric before running production again.
- TempGuard™ This feature was invented in order to control the machine temperature to avoid «overcooling» which results in condensation of water under humid environmental conditions and it saves energy (= no overcooling).
- Wire cooling The wire cooling is essential on high speed welders. It assures best possible welding roll performance and increases the rolls lifetime measurable.
- Wire treatment Like in all Can Man welders, the wire routing is among the most simple ones ever made. Compare it with any of your welders and you'll see the difference.
- EasyACCESS Our daily «field experience» was, is and always will be our most important basic to improve the ergonomics of our products. As a result, with two pushes of a button you'll fully open the complete rollformer unit, lift up the blank magazine, lower the guidance channel, slide aside the body transport system and last but not least unlock and shift forward the calibration tool.
- PowerCONTROL™ is delivered with every X6 WeldCENTER™ and replaces Can Man's redundant control (sliding panel) to give you even more handling flexibility.
- Scoring unit The integration of a scoring unit in combination with a separator allows a production of up to 900 cans per minute, in case your complete production process requires that speed.
- Visit us! A visit in our production facility in Hallwil/Switzerland is the best possibility to get a personal impression of our company as well as of our wide product range. A well-founded technical explanation in front of a welder is better than a theoretical discussion about features and abilities. You're always welcome!

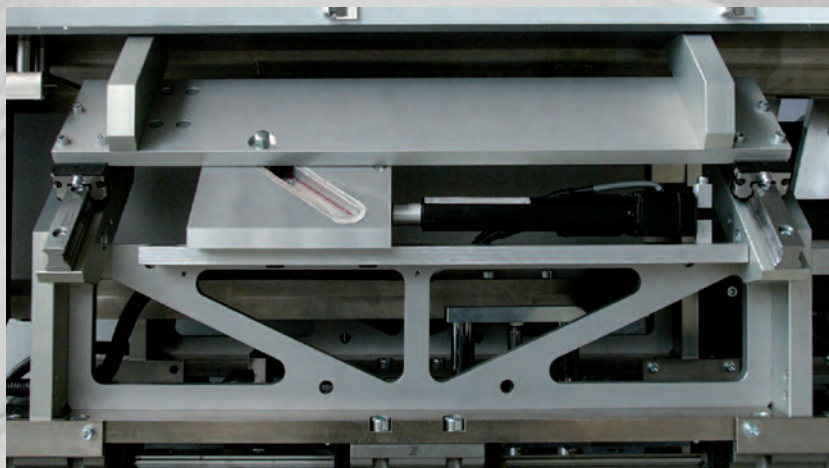

X6-260

X6-320

165

165 mm

52

52

45

45

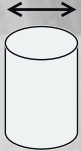

320

320 mm

260

260

50

50

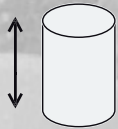

h 320

260

300 cpm

180

400 cpm

100

450 cpm

50



Ø 45

83

99

156 165

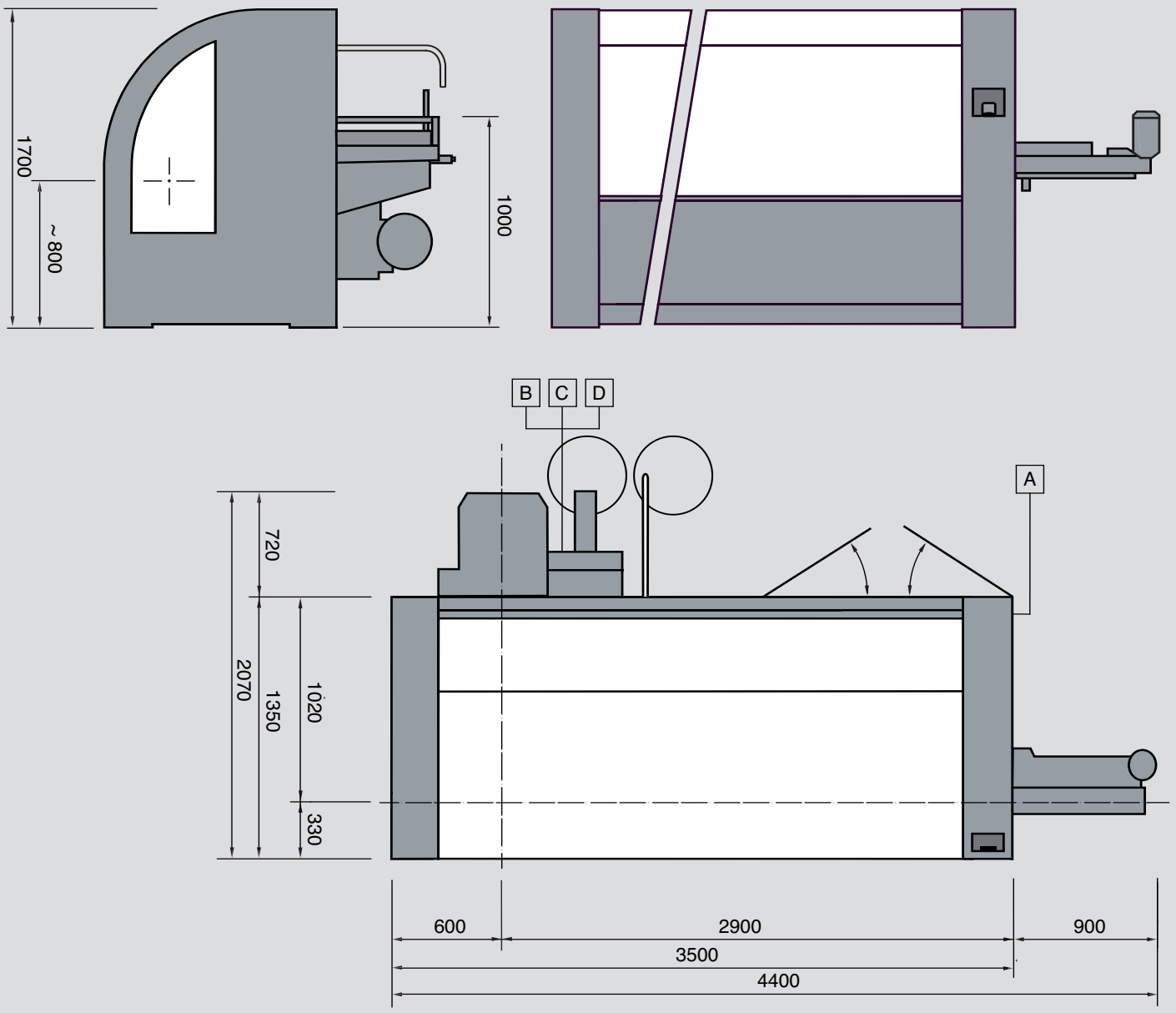

Scale 1:33 ¹/₃

